

INSTALLATION GUIDE

Product Name: BEAM+ IP IP67 Recessed Flexible LED Tape

Product Code: K30-1250*



Kit Contents:

- LED Flexible Tape
- 3M Surface Prep Wipe
- Mounting Brackets
- Closed End Caps
- Silicone Glue

Important Safety Information:

The rated inputting voltage must be 9 -16V DC. You should use a driver to convert the mains voltage to be 9-16V DC.

The luminaire shall under no circumstances be covered with insulating material. During normal use, the object lighted must not exceed a temperature of 95°C. Installation should be carried out by a qualified electrician. This product may contain substances that can be hazardous to the environment if not disposed of properly. Electrical and electronic equipment should never be disposed of with household waste.

Installation: Cut Marks



Make precise vertical cuts at the exact cut position of the light strip.

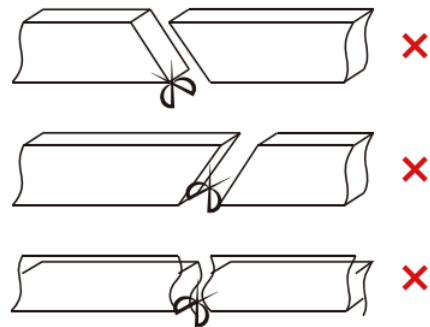

Please do not arbitrarily cut or cut into a bevel and arc section.



+44 (0) 1302 741941 | sales@tlwglobal.com | tlwglobal.com

TLW Global Brunel House, Brunel Close, Harworth, Doncaster, DN11 8QA

INSTALLATION GUIDE

Product Name: BEAM+ IP IP67 Recessed Flexible LED Tape

Product Code: K30-1250*



Installation:

Horizontal Bending (Silicone)

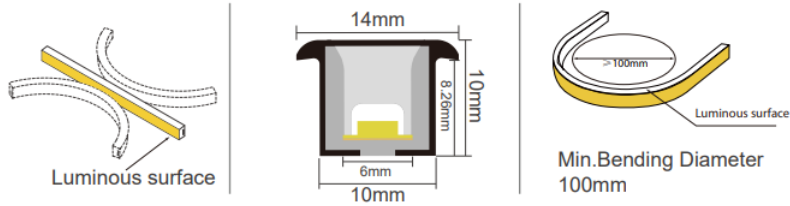

Correct bending way

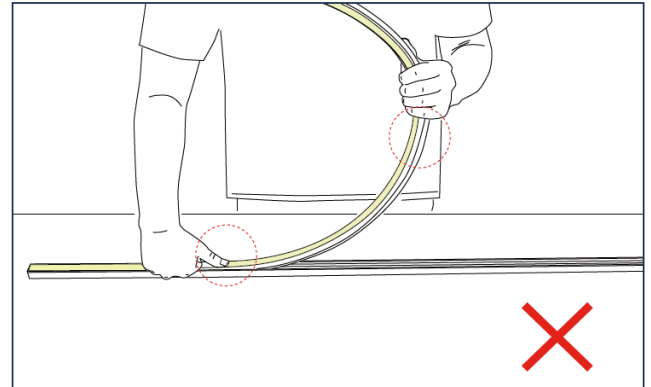
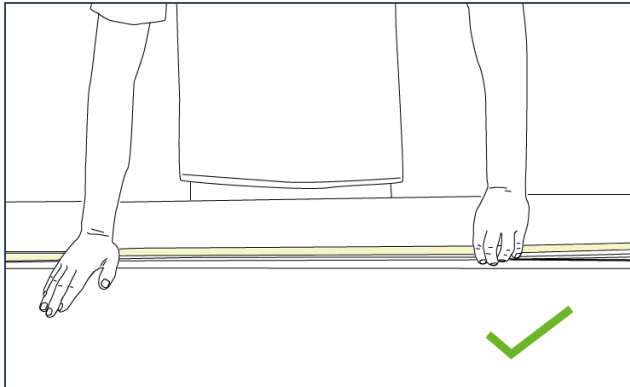

- Please press the led strip with your palm to slowly insert the led strip into the groove, and gently straighten the led strip above the groove with your right hand.
- Try to keep the led strip in a flat state during the installation process.

- Do not press the led strip with a single finger, it is easy to damage the internal parts of the led strip.
- The bent arc of the led strip should not be too large during installation.

Wrong bending way

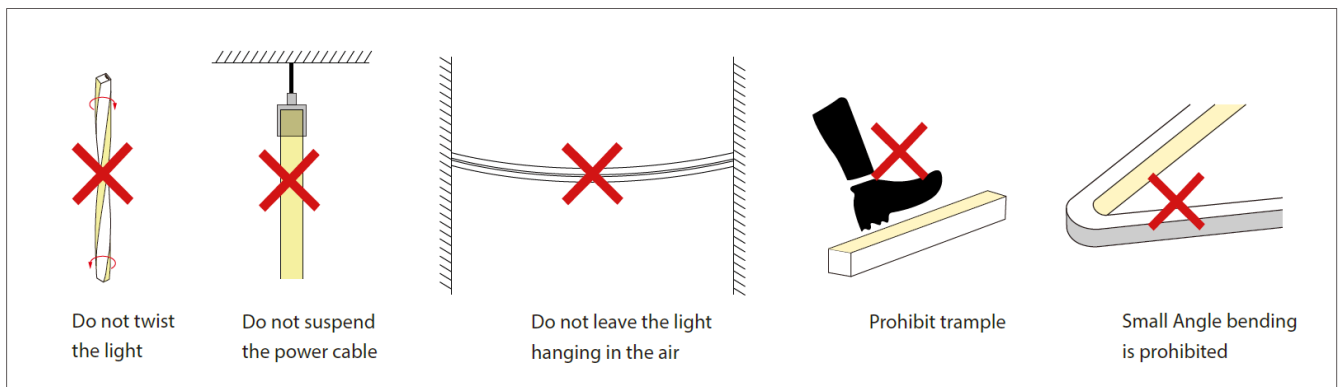

Do not twist the light

Do not suspend the power cable

Do not leave the light hanging in the air

Prohibit trample

Small Angle bending is prohibited



+44 (0) 1302 741941 | sales@tlwglobal.com | tlwglobal.com

TLW Global Brunel House, Brunel Close, Harworth, Doncaster, DN11 8QA

INSTALLATION GUIDE

Product Name: BEAM+ IP IP67 Recessed Flexible LED Tape

Product Code: K30-1250*



This product is suitable for surface mounting or embedded sealing installation. Recommended slot size: Width 10mm, Depth 11-15mm, gently press the neon sleeve into the slot.

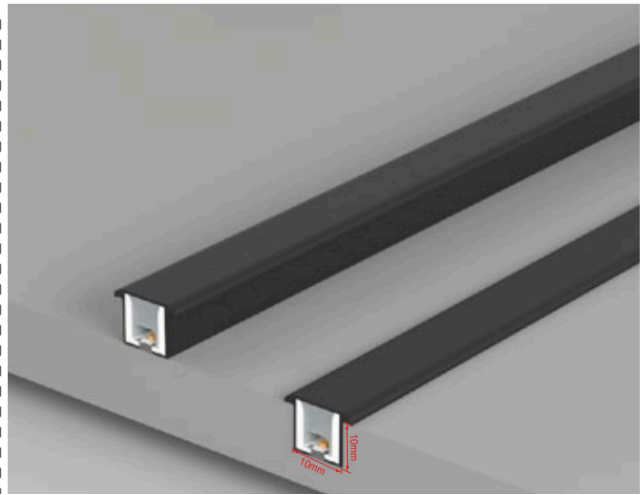
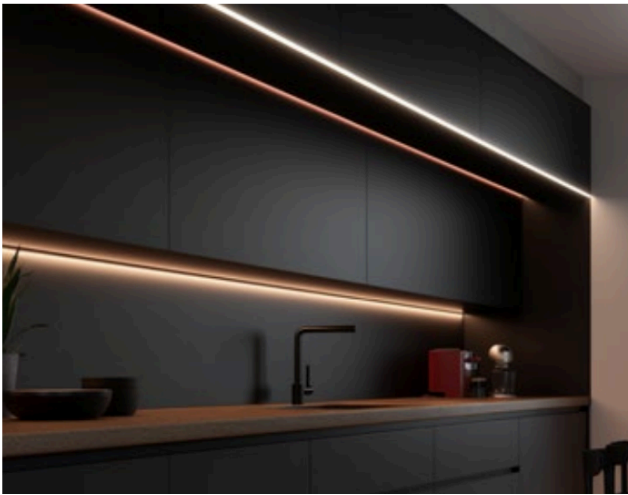

Installation of carrier

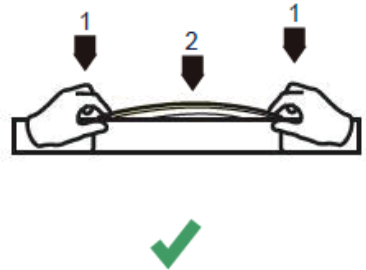
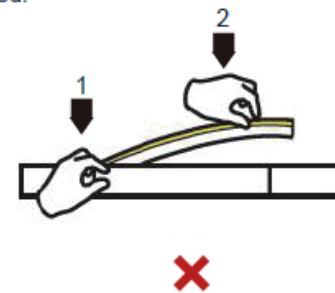
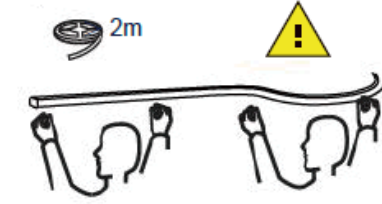
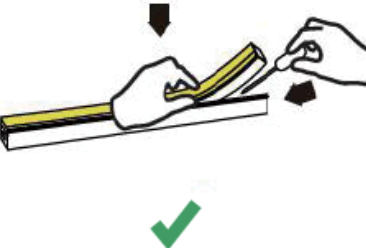
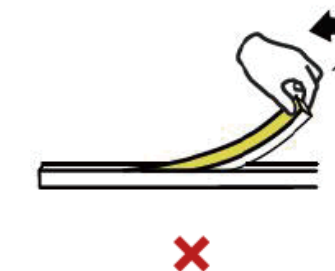
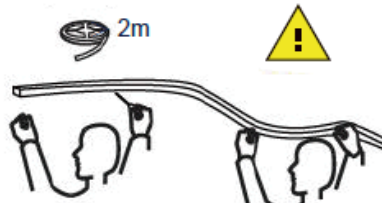
<p>1. When installing the LED strip, install it from both ends at the same time, installation from one direction is prohibited.</p>  	<p>⚠ If the length of LED strip is over 2m, it is recommended to install by two persons.</p> 
<p>2. Use tool to disassemble carefully, and do not pull the LED strip directly.</p>  	<p>⚠ If the length of LED strip is over 2m, it is recommended to disassemble by two persons.</p> 



+44 (0) 1302 741941 | sales@tlwglobal.com | tlwglobal.com

TLW Global Brunel House, Brunel Close, Harworth, Doncaster, DN11 8QA

INSTALLATION GUIDE

Product Name: BEAM+ IP IP67 Recessed Flexible LED Tape

Product Code: K30-1250*



Installation Precautions -- Side Mounted

(If the length of the light is more than 2 meters, two persons must work together to install it.)

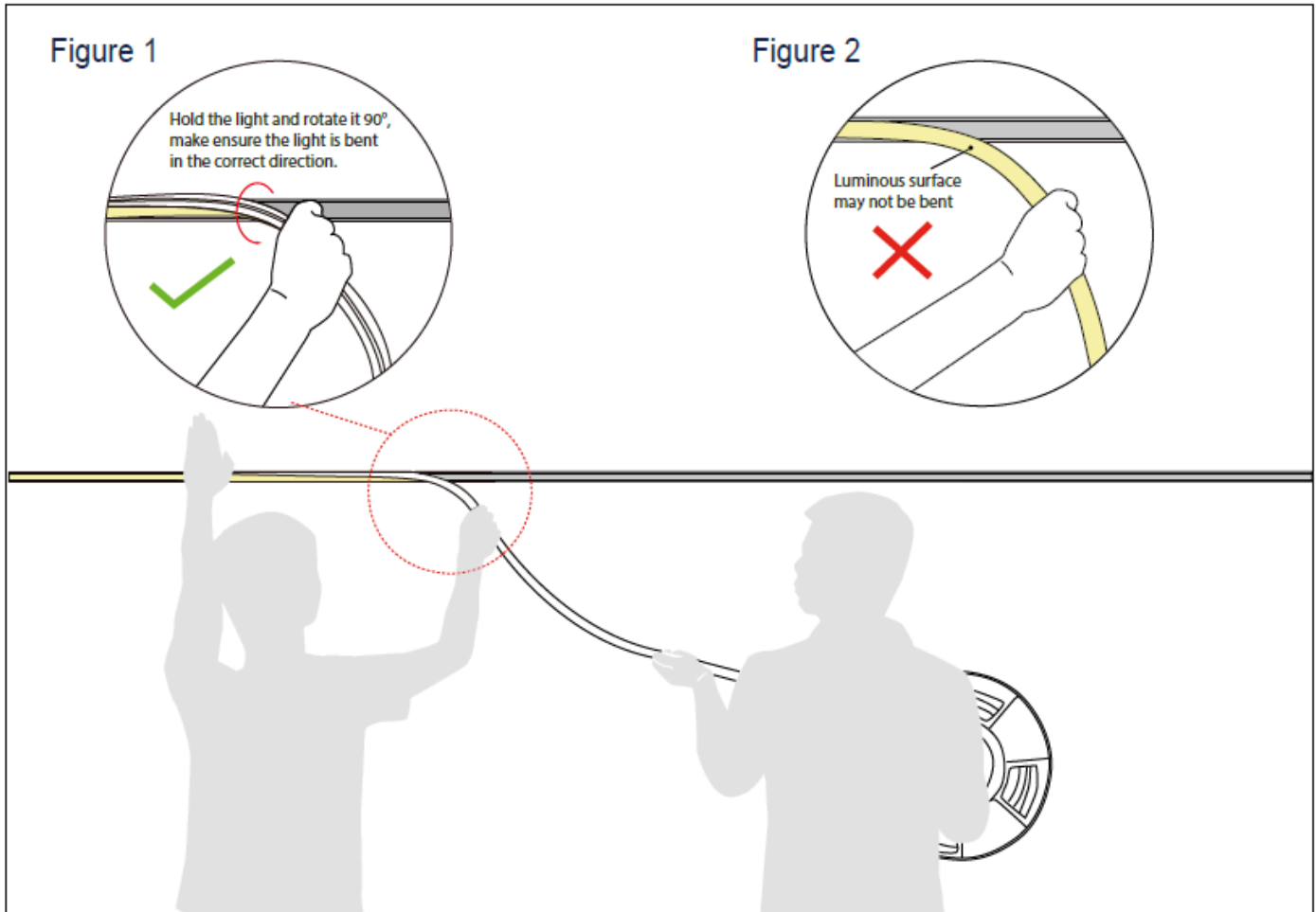

1. Installer:

- Press the light with the palm of the left hand to slowly load it into the slot. Straighten the light with right hand, hold it and rotate it 90° to droop it in the direction of your hand. See Figure 1.
- Do not bend the luminous surface to the side. See Figure 2.

2. Assistant:

- Cooperate with the installer to lift the reel of the light, and then slowly deliver the light to installer. Do not pull or twist the light during the installation.



+44 (0) 1302 741941 | sales@tlwglobal.com | tlwglobal.com

TLW Global Brunel House, Brunel Close, Harworth, Doncaster, DN11 8QA