

INSTALLATION GUIDE



Product Name: WIRELESS DIMMER TOUCH SENSOR

Product Code: N28-1005

Important Safety Information:

- Turn off and isolate the electrical supply before connecting this fitting to the building wires.
 - Must be installed or connected by a licensed electrician.
 - The luminaries are intended for indoor use only
-



Product Overview

The Wireless Dimmer Touch Sensor operates using 2.4GHz wireless radio frequency technology and can be paired with a compatible receiver to enable wireless lighting control.

Powered by a replaceable CR2450 button cell battery, the sensor can control the wireless receiver from a distance of up to 10 metres in open spaces.

This product offers an energy-efficient, environmentally friendly, and wire-free solution for convenient furniture LED lighting control.

Technical Specifications

Ambient Temperature -20°C to 50°C

Operating Voltage 3.0V to 3.3V

Battery Type CR2450

Modulation Method GFSK

Standby Power Consumption < 0.2mW

Operating Power Consumption < 60mW

Wireless Transmission Frequency 2.4GHz

Receiver to Sensor Range Up to 10 metres

Product Dimensions 50 × 40 × 11.5 mm



+44 (0) 1302 741941 | sales@tlwglobal.com | tlwglobal.com

TLW Global Brunel House, Brunel Close, Harworth, Doncaster, DN11 8QA

INSTALLATION GUIDE



Product Name: WIRELESS DIMMER TOUCH SENSOR

Product Code: N28-1005

Product Dimensions and Wood Panel Installation

Dimensions: 50 mm (width) × 40 mm (height) × 11.5 mm (depth)

Installation Notes:

Surface Mounting

- Use screws to fix the mounting base in the desired position on the cabinet surface.
- Slide and snap the controller into the mounting base to complete installation.

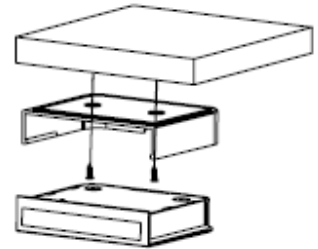

Recessed Mounting

- Cut slots at the edge of the panel or laminate as shown below:
 - Depth: 10mm
 - Width: $48.8 \pm 0.2\text{mm}$
 - Height: $38.7 \pm 0.2\text{mm}$
- Insert the controller into the recess and secure using the provided clip.

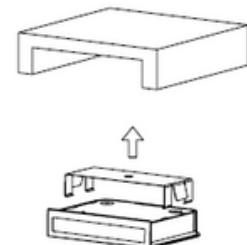
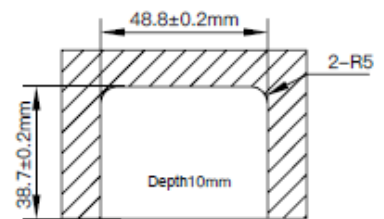

Initial Setup

1. Remove the battery insulation tab before use.
2. Connect the lighting fixtures to the sensor, then power up the device.
3. Within 30 seconds of powering on, press and hold the code button on the sensor.
4. The fixtures will flash three times to confirm successful pairing.
5. The remote control can now operate this group of fixtures.

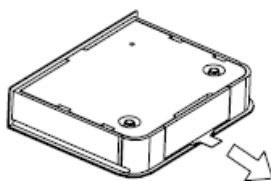

Initial use: Remove the battery insulation tabs

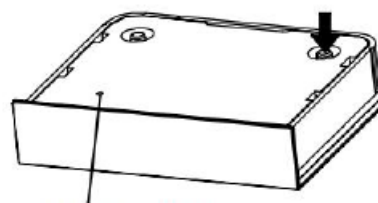

Indicator light



+44 (0) 1302 741941 | sales@tlwglobal.com | tlwglobal.com

TLW Global Brunel House, Brunel Close, Harworth, Doncaster, DN11 8QA

Product Name: WIRELESS DIMMER TOUCH SENSOR

Product Code: N28-1005

Wireless Pairing, Clearing Codes, and Learning Function

Pairing the sensor and Receiver

- After powering on the receiver, press and hold the pair code button on the receiver for 5 seconds.
- The lamp will flash three times, confirming successful pairing.



Clearing Codes

- With the receiver powered on, press and hold the pair code and clear code buttons simultaneously for around 5 seconds.
- The lamp will flash three times to confirm that the pairing has been cleared.
- The remote control will no longer operate this receiver.

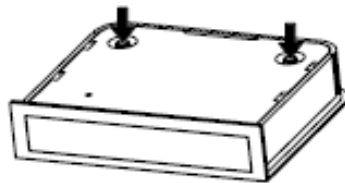

Learning Between Sensors - To Pair sensors A and B:

Uncoded Sensor B:
Long press the code key for 5 seconds, the indicator light is always on at this time to enter the learning state.

Sensor A: Long press the code key for 2 seconds, the indicator light of sensor B will turn off.
Successful learning, sensor A,B can control the same receiver.



INSTALLATION GUIDE



Product Name: WIRELESS DIMMER TOUCH SENSOR

Product Code: N28-1005

To Clear the Code:

Press and hold the clear code key for 5 seconds, the sensor indicator goes out. The code value is cleared successfully.

This function is only effective when the sensor has learned the code value of other the other sensor.

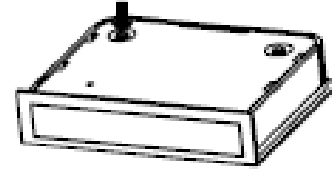

Battery Replacement:

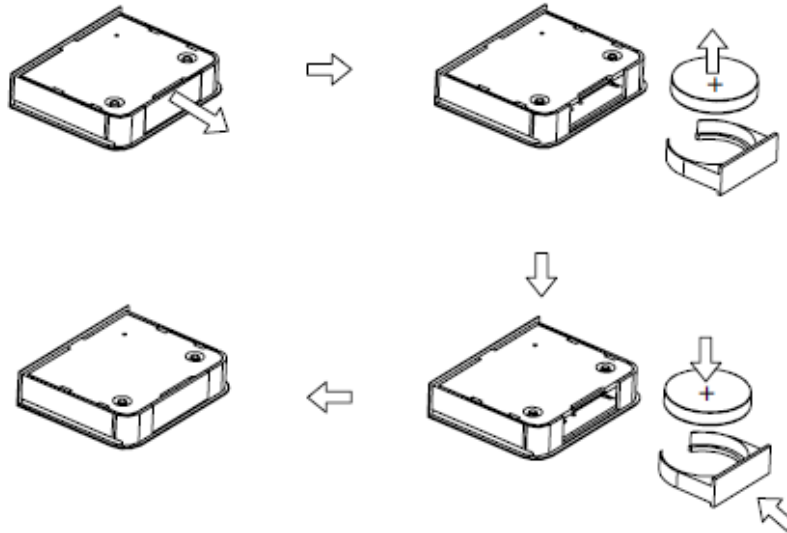

Important Safety Information

Do not enclose the sensor or receiver in metal housings, and avoid obstructions between them.

If the sensor does not function, check and replace the battery if necessary.

Do not dispose of the sensor in fire or immerse it in liquids.

Handle with care – avoid strong impact, vibration, or compression.

To prevent accidental triggering or power waste, avoid placing objects in contact with the sensor surface.



+44 (0) 1302 741941 | sales@tlwglobal.com | tlwglobal.com

TLW Global Brunel House, Brunel Close, Harworth, Doncaster, DN11 8QA